

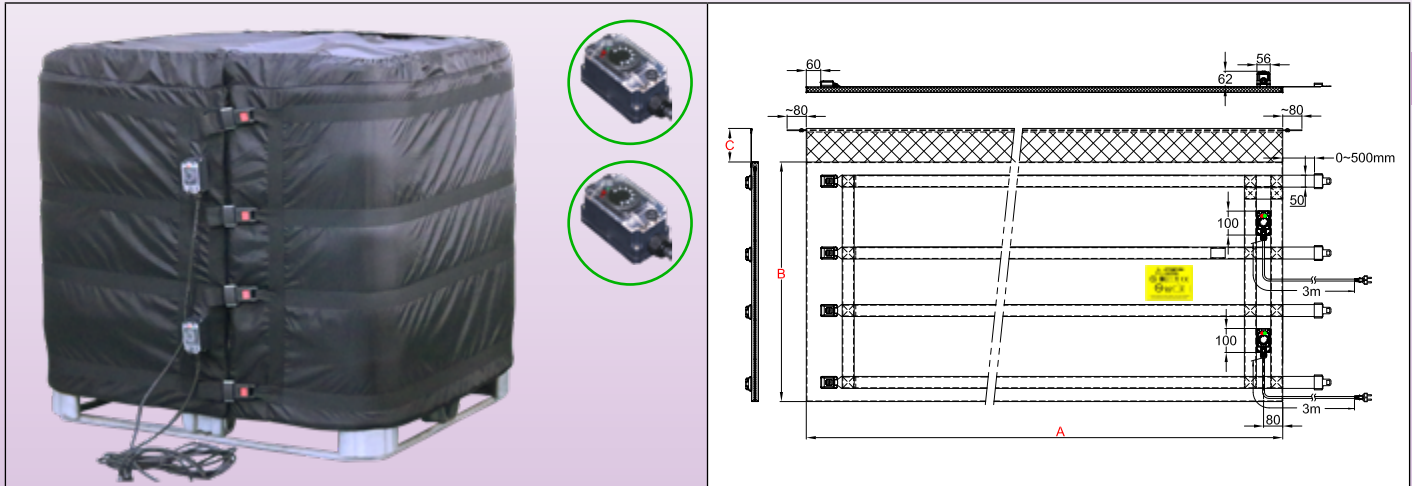

Because of permanent improvement of our products, drawings, descriptions, features used on these data sheets are for guidance only and can be modified without prior advice

Containers material	Maximum temperature limited to :	Tightening	Thermostat	Insulation thickness	Type
Plastic with tubular steel frame	135°C	Nylon straps and metal buckle	2 Electronic, set point adjustable by knobs from 20 to 125°C	20mm	9VJBE



Main Features

Thanks to its two miniature electronic thermostats, adjustable by knob from 20 to 125°C, this series of flexible jacket heaters with 2 heating zones with 2 independent temperature controls are used for antifreeze protection, reheating, temperature stabilization, to reduce viscosity or to melt soaps, animal or vegetable fats, varnishes, oils, food or chemical products.

This series of jacket heaters is the most economical solution, with for heating at a set temperature 1000 liters bulk containers (IBC) of 1m x 1.20m and height 1m. For heating half empty containers, it is possible to heat only the lower zone. The jacket heater covers the entire surface and is surmounted by a soft collar (Scarf) preventing sliding down. They are made with three power levels: (0.05W/cm² for temperature up to 50°C, 0.1W/cm² for temperature up to 80°C, and 0.135W/cm² for temperature up to 110°C. Their thickness of insulation is 20mm. In these models the surface temperature is limited to 135°C. They can therefore be used on full metal 1000 liters IBC, and provided that the set points of the electronic regulators are set at sufficiently low temperatures, on plastic containers. When they are used with an insulated lid and an insulated pedestal, their energetic efficiency can rise 90%.

Technical characteristics

The heating element of the flexible jacket heater consists of a network of silicone insulated heating wires shielded by a metal braid, taken under a cover sewn in PU and Teflon coated polyester fabric. A 20mm thick, temperature-resistant NBR-PVC foam insulation is inserted between the heating network and the outer wall. This insulating foam has an insulation coefficient (Lambda λ) of 0.039W/m.K, and this makes it possible to divide the energy losses by 3 compared to jacket heaters insulated with mineral wool or carbon fiber felt of the same thickness. Adjustable metal buckles allow quick assembly and disassembly and efficient clamping on the container. Their mechanical strength is exceptional.

Fabric covering:

- Internal heating face: Teflon coated polyester fabric,
- External side: waterproof PU coated polyester fabric.

Thermal insulation:

NBR-PVC foam, with closed cells and high temperature resistance, thickness 20mm.

Heating element:

Silicon insulated heating wire with metal braid providing mechanical protection against puncturing and good grounding.

Temperature control:

Each of the 2 heating zones has its own electronic thermostat adjustable from 20 to 125°C, located in a waterproof box mounted on the external surface of the jacket heater. It controls the temperature by means of a thermistor probe placed on the inner surface of the fabric in contact with the container. This probe has an anticipation loop avoiding overheating. Each of the 2 heating zones has also its own temperature limiter, incorporated in the heating net to limit the surface temperature to 135°C.

Jacket heaters for 1000L IBC containers. Two independent heating zones. 2 Miniature electronic thermostats, adjustment by 20-125°C knobs, mounted on jacket surface



Connection cable:

Each of the 2 heating zones has its own rubber insulated power supply cable, for industrial environments, 3x1.5mm², length 3m, with Euro plug. UL plug on request.

Mounting on containers:

These jacket heaters feature nylon straps with quick-release adjustable buckles and a soft fabric collar without thermal insulation named scarf. This flexible scarf can be used to hold in place a flat insulating lid

Options:

- Electronic thermostat temperature range -40+40°C, 30-90°C, 30-110°C
- Power supply 110/115V
- Power cord with industrial plug 2-pole + earth 16A CEE (IEC60309)
- Lids and insulating pedestals: see the accessories pages.

Compliance with standards: CE compliant. TUV certificate for EEC Low Voltage Directive (LVD) and EMC directive 2004/108/EC, and CE marked accordingly.

Main reference (see the technical introduction for the liquids heating time)

References*	Volume, US gallons	Volume, Liters	Dia. (mm ± 12; Inch ± ½")	Height A (mm/inch)	Flat length B (mm/inch)	Scarf C (mm/inch)	w/cm ² (W/in ²)**	Max temp. °C	Watt	Voltage V
9VJBEA0D398B205G	264	1000	1000 x 1200 (39.4 x 47.3)	1000 (39.4)	4390 (172.8)	100 (3.9)	0,05 (0.32)	50	2x1100	220/240
9VJBEA0D398D405G	264	1000	1000 x 1200 (39.4 x 47.3)	1000 (39.4)	4390 (172.8)	100 (3.9)	0.1 (0.64)	80	2x2200	220/240
9VJBEA0D398F005G	264	1000	1000 x 1200 (39.4 x 47.3)	1000 (39.4)	4390 (172.8)	100 (3.9)	0.135 (0.87) **	110	2x3000	220/240

* For these products supplied with UL plug and not Euro plug, replace the 15th character by X.

** Surface load not recommended for direct contact with plastic containers.

Because of permanent improvement of our products, drawings, descriptions, features used on these data sheets are for guidance only and can be modified without prior advice